

## OPZIONI

- » Modello con distributore a disco roll-gerotor
- » Motori in versione flangia o ruota
- » Motori corti
- » Connessione tachimetrica
- » Sensore di velocità
- » Attacchi tubazioni laterali
- » Alberi cilindrici, conici, dentati
- » Filettature metriche o BSPP
- » Altre caratteristiche speciali

## OPTIONS

- » Model- Disc valve, roll-gerotor
- » Flange with wheel mount
- » Short motor
- » Tacho connection
- » Speed sensing
- » Side ports
- » Shafts- straight, splined and tapered
- » Metric and BSPP ports
- » Other special features

Cilindrata	<i>Displacement</i>	cm <sup>3</sup> /rev	314,5 ÷ 801,8
Velocità Max.	<i>Max. Speed</i>	min <sup>-1</sup>	250 ÷ 510
Coppia Max.	<i>Max. Torque</i>	daNm	92 ÷ 188
Potenza Max.	<i>Max. Output</i>	kW	42,5 ÷ 53,5
Caduta di Pressione Max.	<i>Max. Pressure Drop</i>	bar	160 ÷ 200
Portata Max.	<i>Max. Oil Flow</i>	l/min	160 ÷ 200
Velocità min.	<i>Min. Speed</i>	min <sup>-1</sup>	5 ÷ 10
Carico sull'albero ammesso	<i>Permissible Shaft Loads</i>	daN	P <sub>a</sub> = 1500
Fluido Idraulico	<i>Recommended Fluid</i>		Base minerale- HLP(DIN 51524) o HM(ISO 6743/4) Mineral based- HLP(DIN 51524) or HM(ISO 6743/4)
Campo Temperatura	<i>Temperature range</i>	°C	-30 ÷ 90
Campo Viscosità Ottimale	<i>Optimal Viscosity range</i>	mm <sup>2</sup> /s	20 ÷ 75
Filtrazione	<i>Filtration</i>		ISO classe 20/16 (Filtrazione minima raccomandata 25 micron) ISO code 20/16 (Min. recommended fluid filtration of 25 micron)

### Portata olio linea drenaggio Oil flow in drain line

Caduta di Pressione	<i>Pressure drop</i>	bar	100		140	
Viscosità	<i>Viscosity</i>	mm <sup>2</sup> /s	20	35	20	35
Drenaggio	<i>Oil flow in drain line</i>	l/min	<b>2,5</b>	<b>1,8</b>	<b>3,5</b>	<b>2,8</b>

### Caduta di Pressione Pressure Drop

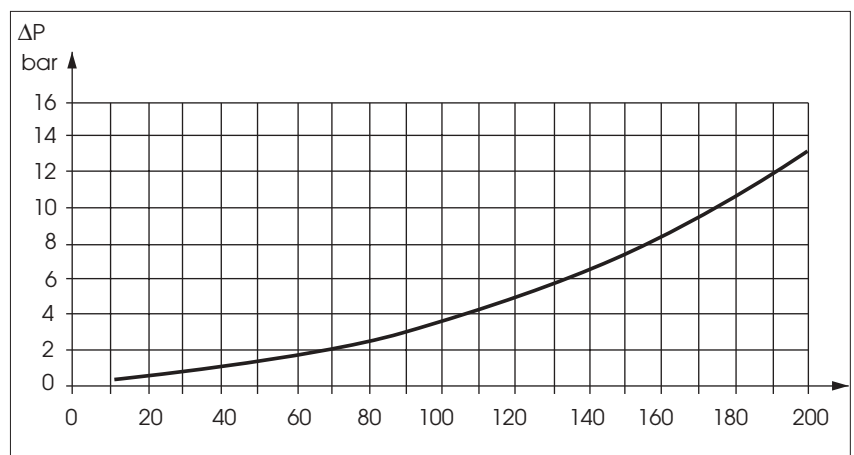

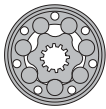

## DATI TECNICI / SPECIFICATION DATA

			GLV 315	GLV 400	GLV 500	GLV 630	GLV 800	
Cilindrata	<i>Displacement</i>	cm <sup>3</sup> /rev	314,5	400,9	499,6	629,1	801,8	
Velocità Max	<i>Max. Speed</i>	min <sup>-1</sup>	cont. / cont.	510	500	400	315	250
			int.* / int.*	630	600	480	380	300
Coppia Max	<i>Max. Torque</i>	daNm	cont. / cont.	92	118	146	166	188
			int.* / int.*	111	141	176	194	211
			picco** / peak**	129	164	205	221	247
Potenza Max.	<i>Max. Output</i>	kW	cont. / cont.	42,5	53,5	53,5	48	42,5
			int.* / int.*	51	64	64	56	48
Caduta di Pressione Max.	<i>Max. Pressure Drop</i>	bar	cont. / cont.	200	200	200	180	160
			int.* / int.*	240	240	240	210	180
			picco** / peak**	280	280	280	240	240
Portata Max.	<i>Max. Oil Flow</i>	l/min	cont. / cont.	160	200	200	200	200
			int.* / int.*	200	240	240	240	240
Pressione Max. in ingresso	<i>Max. Inlet Pressure</i>	bar	cont. / cont.	210	210	210	210	210
			int.* / int.*	250	250	250	250	250
			picco** / peak**	300	300	300	300	300
Pressione Max. sul ritorno senza drenaggio o Max. Pressione linea drenaggio	<i>Max. Return Pressure without Drain Line or Max. Pressure in Drain Line</i>	bar	cont. 0-100 min <sup>-1</sup>	60	60	60	60	60
			cont. 100-300 min <sup>-1</sup>	30	30	30	30	30
			cont. > 300 min <sup>-1</sup>	20	20	20	20	20
			int.* 0-max min <sup>-1</sup>	75	75	75	75	75
Pressione Max. sul ritorno con drenaggio	<i>Max. Return Pressure with Drain Line</i>	bar	cont. / cont.	140	140	140	140	140
			int.* / int.*	175	175	175	175	175
			picco** / peak**	210	210	210	210	210
Max pressione di avviam. a vuoto	<i>Max. Start. Pressure with Unloaded Shaft</i>	bar	8	8	8	8	8	
Coppia di Spunto Min.	<i>Min. Starting Torque</i>	daNm		71	91	113	133	151
				85	109	136	155	170
Velocità Min***	<i>Min. Speed***</i>	min <sup>-1</sup>	10	9	8	6	5	
Peso	<i>Weight</i>	kg	GLV Q	31,8	32,6	33,5	34,9	36,5
			GLV W	32,4	33,2	34,1	35,5	37,1
			GLV U	22,7	23,5	24,4	25,6	27,7

\* Servizio Intermittente: i valori ammessi si intendono per un massimo del 10% ogni minuto

\*\* Valori di Picco : i valori ammessi si intendono per un massimo dell'1% ogni minuto

\*\*\* Per velocità di 10 giri/min o inferiori, consultare il produttore

- Velocità e caduta di pressione max intermittenti non devono verificarsi simultaneamente
- Filtrazione raccomandata classe contaminazione ISO4406 20/16 o migliore. Una filtrazione nominale di 25 micron o migliore
- Si raccomanda l'impiego di un fluido idraulico a base minerale di qualità con additivi anti-usura tipo HLP(DIN51524) or HM (ISO6743/4). Per l'utilizzo di fluidi sintetici consultare il produttore.
- Viscosità minima raccomandata alla temperatura di lavoro 13 mm<sup>2</sup>/s
- Temperatura massima raccomandata nel sistema è 82 °C.
- Per assicurare il buon funzionamento riempire il motore con il fluido idraulico e azionarlo a bassa velocità e moderato carico per 10-15 minuti.

\* Intermittent operation: the permissible values may occur for max. 10% of every minute.

\*\* Peak load: the permissible values may occur for max. 1% of every minute.

\*\*\* For speeds of 10 RPM or lower, consult factory or your regional manager.

- Intermittent speed and intermittent pressure drop must not occur simultaneously.
- Recommended filtration is per ISO cleanliness code 20/16. A nominal filtration of 25 micron or better
- Recommended using a premium quality, anti-wear type mineral based hydraulic oil HLP(DIN51524) or HM (ISO 6743/4). If using synthetic fluids consult the factory for alternative seal materials.
- Recommended minimum oil viscosity 13 mm<sup>2</sup>/s at operating temperatures.
- Recommended maximum system operating temperature is 82 C.
- To assure optimum motor life fill with fluid prior to loading and run at moderate load and speed for 10-15 minutes.

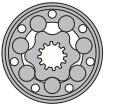

## DIAGRAMMI DI FUNZIONAMENTO / FUNCTION DIAGRAMS

### GLV 315

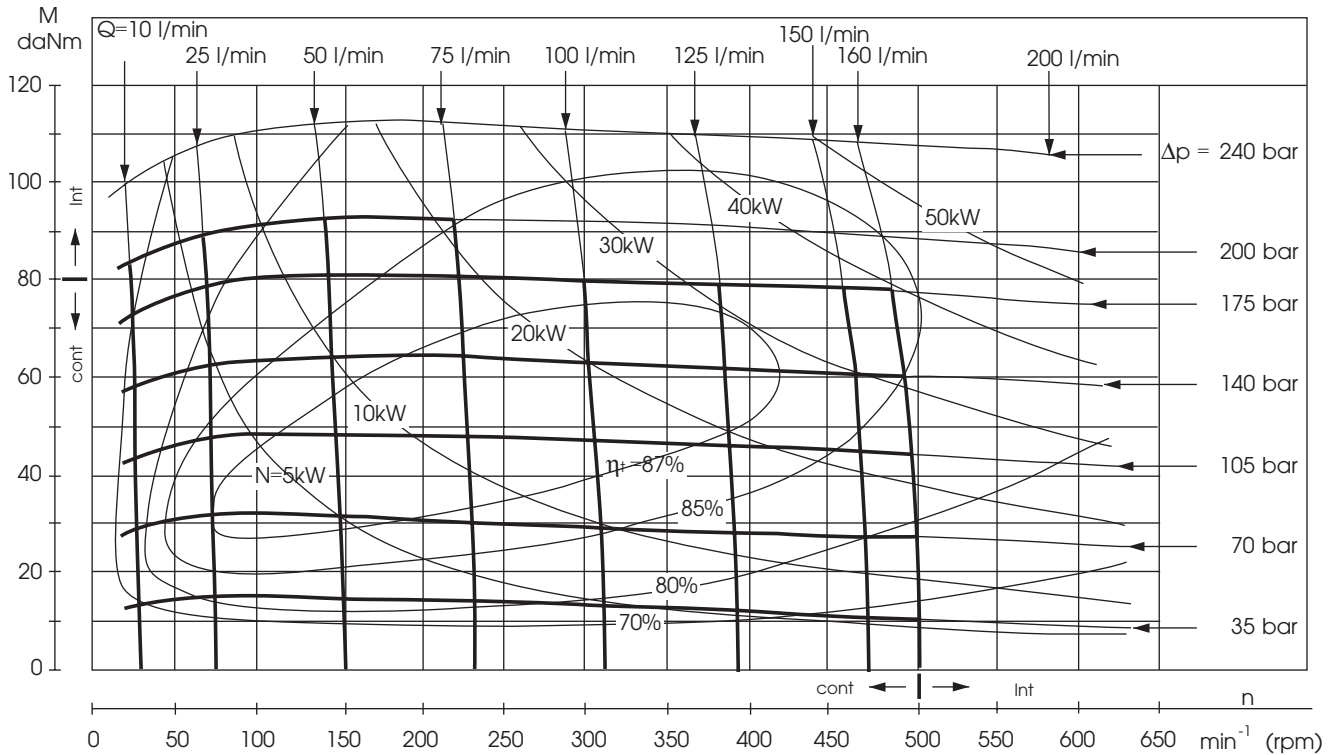

### GLV 400

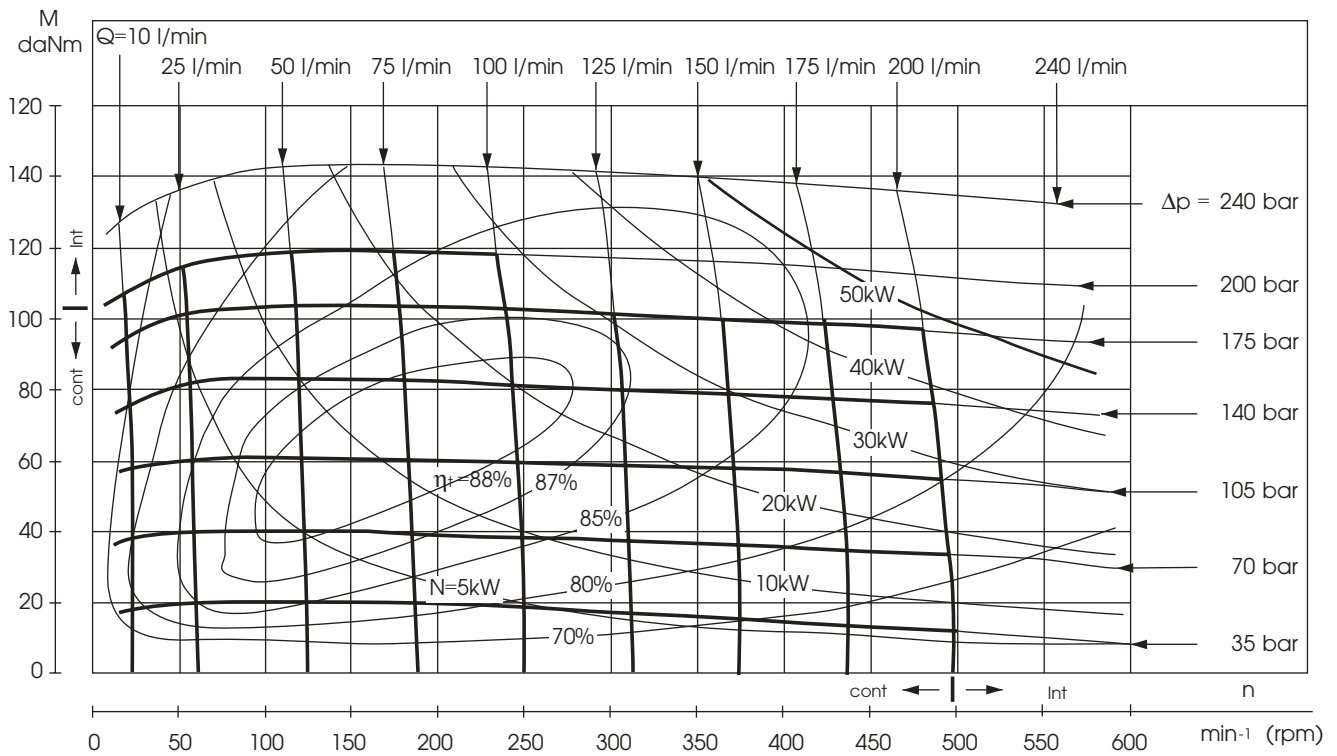

Condizioni di prova, contropressione 5÷10 bar, viscosità fluido idraulico 32  $\text{mm}^2/\text{s}$  alla temperatura di 50° C.  
 The function diagrams data was collected at back pressure 5÷10 bar and oil with viscosity of 32  $\text{mm}^2/\text{s}$  at 50° C.

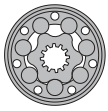

## DIAGRAMMI DI FUNZIONAMENTO / FUNCTION DIAGRAMS

### GLV 500

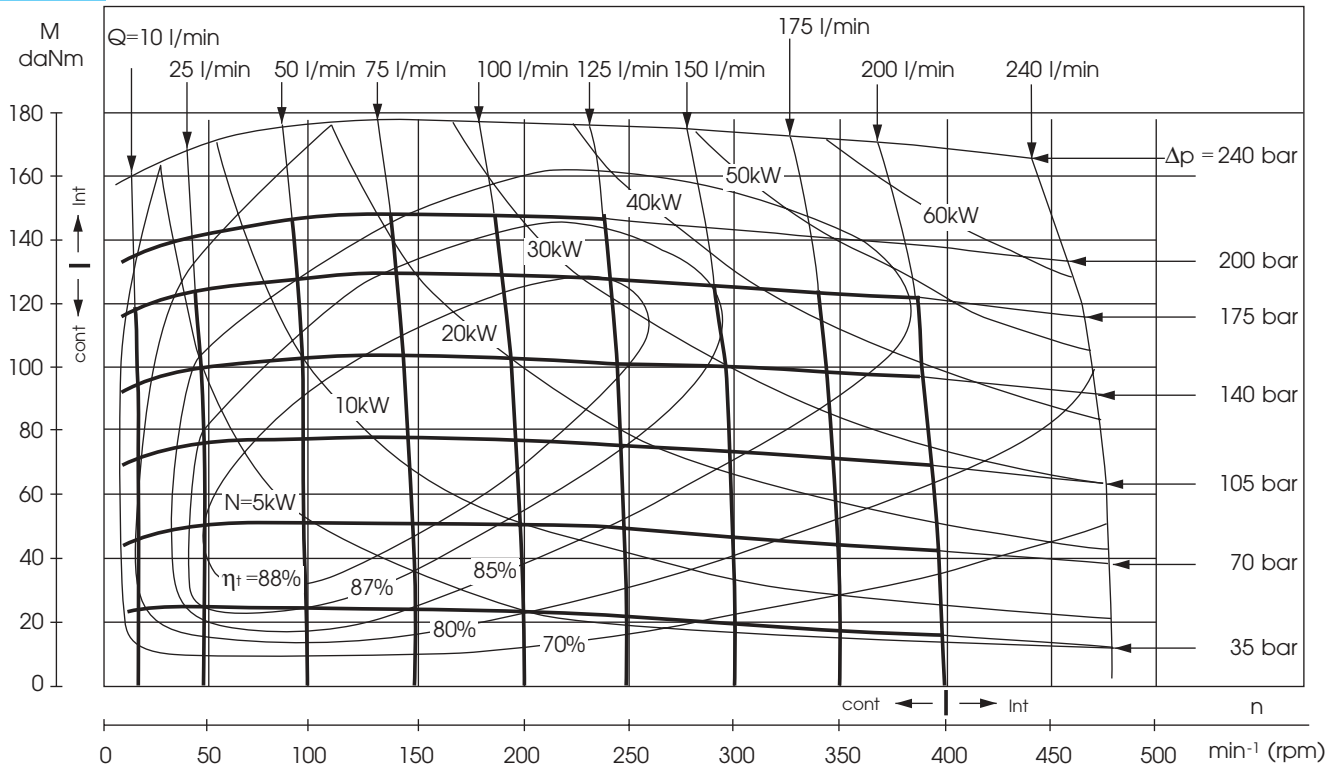

### GLV 630

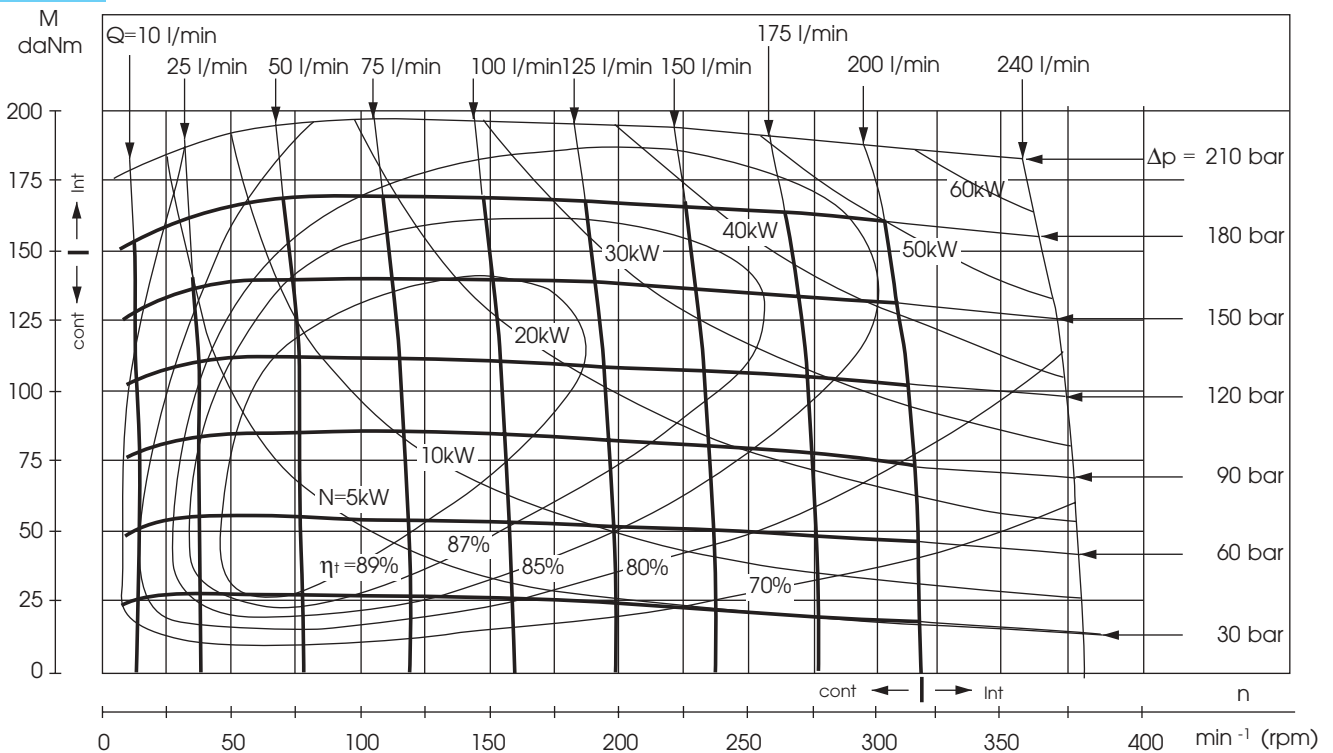

Condizioni di prova, contropressione 5÷10 bar, viscosità fluido idraulico 32 mm<sup>2</sup>/s alla temperatura di 50° C.  
The function diagrams data was collected at back pressure 5÷10 bar and oil with viscosity of 32 mm<sup>2</sup>/s at 50° C.

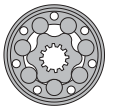

## DIAGRAMMI DI FUNZIONAMENTO / FUNCTION DIAGRAMS

**GLV  
800**

M  
daNm

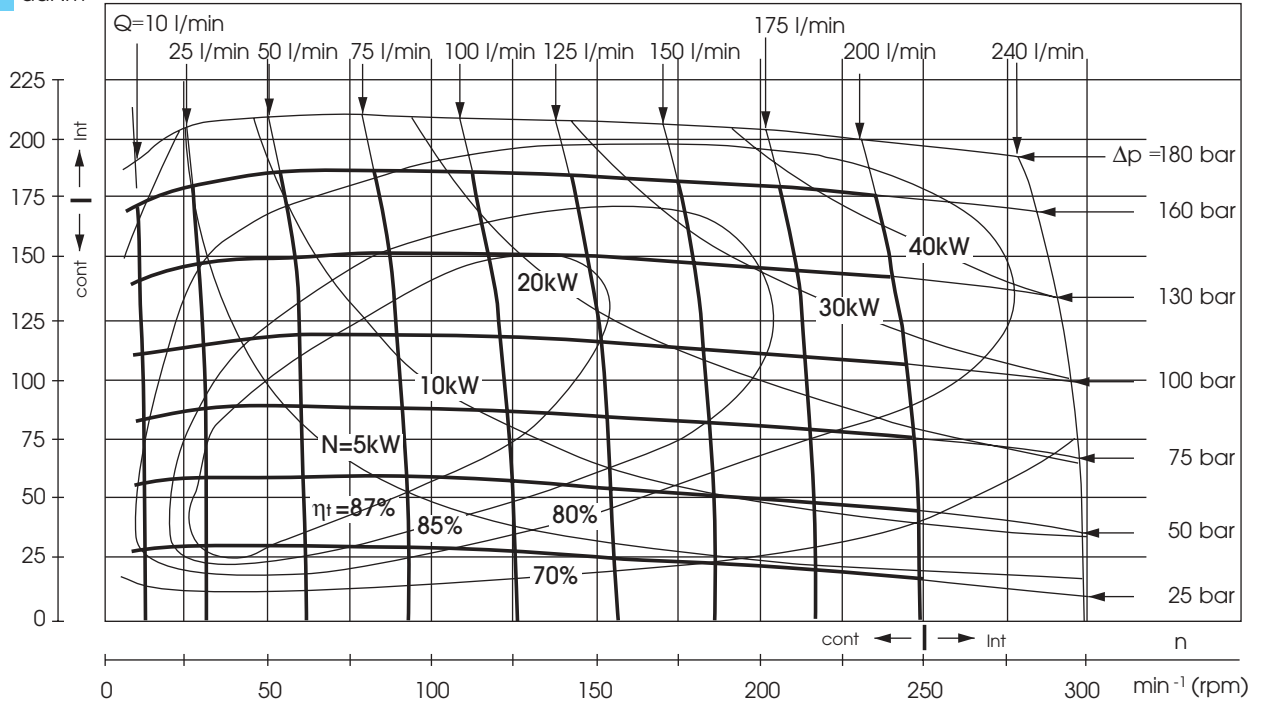

## CARICO AMMESSO SULL'ALBERO / PERMISSIBLE SHAFT LOADS

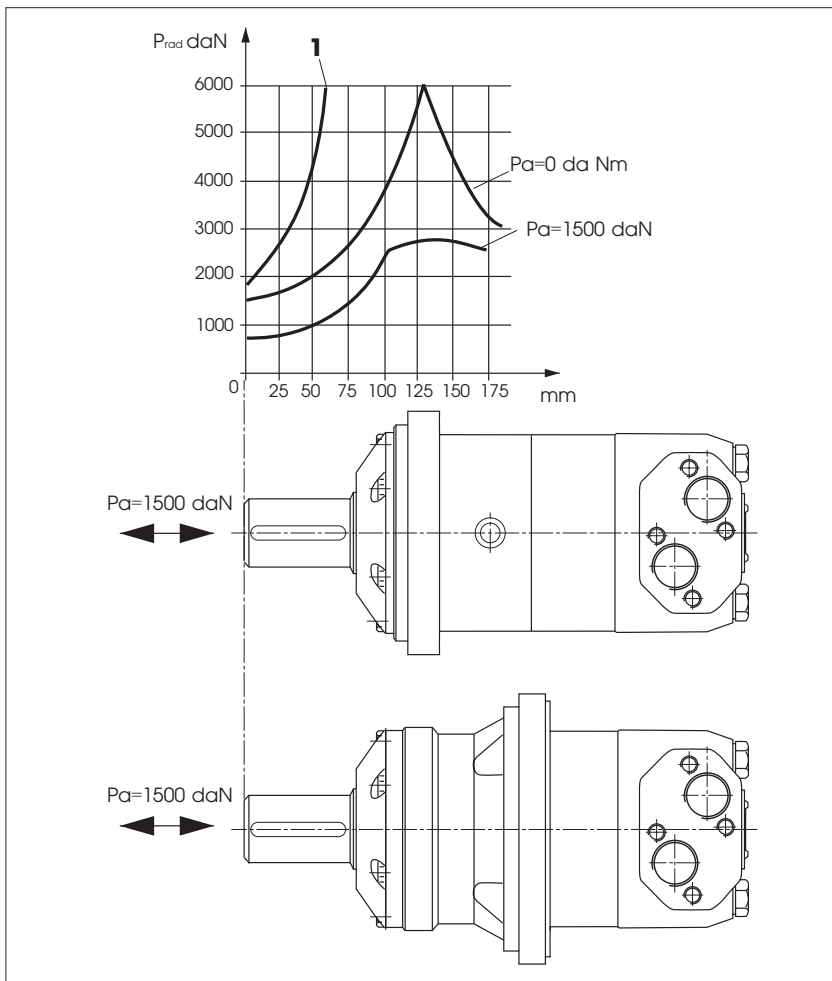

The output shaft runs in tapered bearings that permit high axial and radial forces. Curve "1" shows max. radial shaft load. Any shaft load exceeding the values quoted in the curve will seriously reduce motor life. The two other curves apply to a B10 bearing life of 3000 hours at 200 RPM.

L'albero di uscita è supportato da cuscinetti conici che permettono un elevato carico assiale e radiale. La curva "1" mostra il carico radiale massimo. Un carico superiore alla curva "1" riduce in modo grave la vita del motore. Le altre due curve si riferiscono a cuscinetti classe B10 con durata di 3000 ore a 200 giri/min lubrificati in olio idraulico minerale.

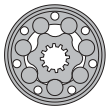

# GLV

## DIMENSIONI / DIMENSIONS GLV

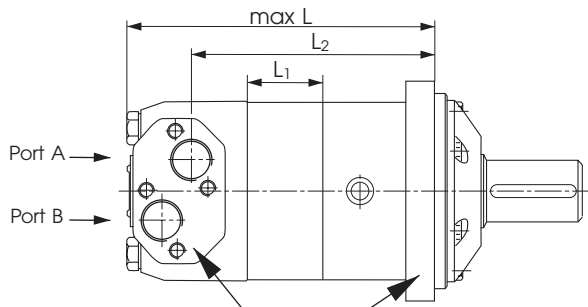

### Connessioni Connections

#### 2 Attacchi laterali Side ports

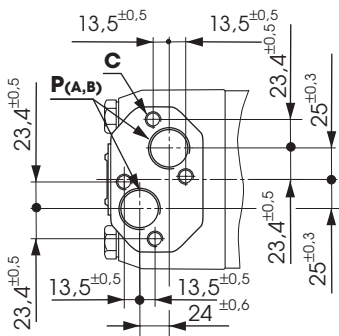

### Flangia/Mounting

#### Q Flangia quadrata Square mount

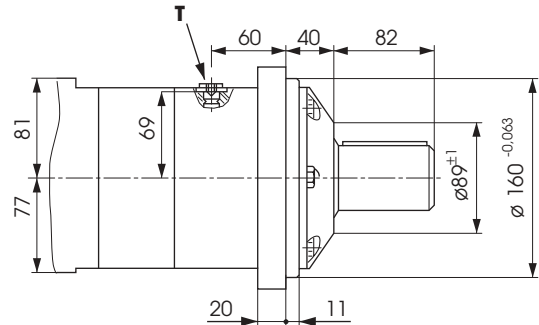
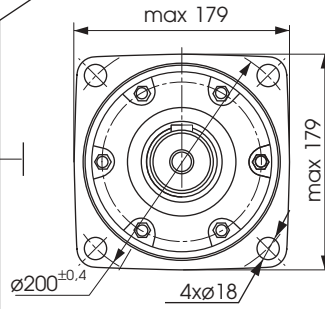

#### E SAE C flangia SAE C mount

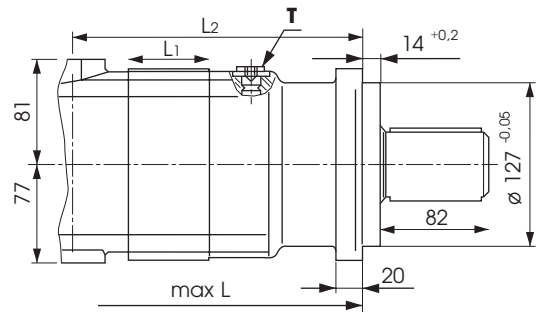
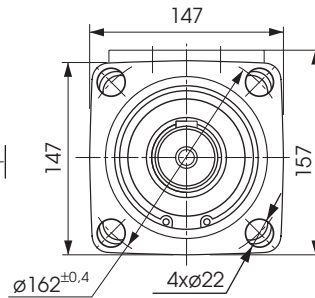

#### W Motore ruota Wheel mount

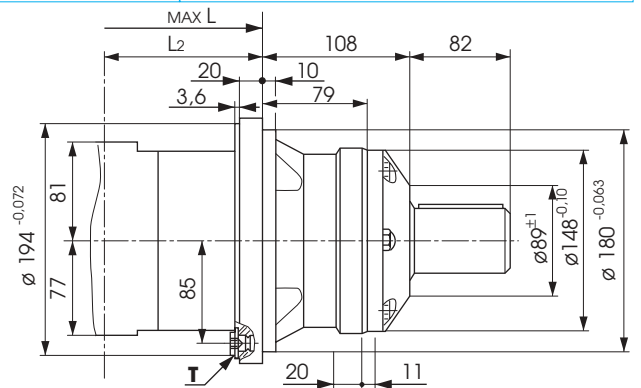
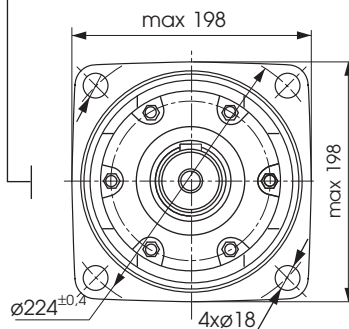

	Filettatura/Thread	Profondità Depth
C	4 x M12	12 mm
A, B	2 x G 1"	20 mm
T*	G 1/4"	12 mm

\* tappato - plugged

**Rotazione Standard** Visto con l'albero di fronte  
Attacco A pressurizzato - CW  
Attacco B pressurizzato - CCW

**Rotazione Inversa** Visto con l'albero di fronte  
Attacco A pressurizzato - CCW  
Attacco B pressurizzato - CW

**Standard Rotation** Viewed from Shaft End  
Port A Pressurized - CW  
Port B Pressurized - CCW

**Reverse Rotation** Viewed from Shaft End  
Port A Pressurized - CCW  
Port B Pressurized - CW

Tipo / Type	L, mm	L2, mm	Tipo / Type	L, mm	L2, mm	Tipo / Type	L, mm	L2, mm	L1, mm
GLV 315 Q2	214,5	160	GLV 315 E2	238,25	184,26	GLV 315 W2	146	92	21,5
GLV 400 Q2	221,5	167	GLV 400 E2	245,25	191,26	GLV 400 W2	153	99	28,5
GLV 500 Q2	229,5	175	GLV 500 E2	253,25	199,26	GLV 500 W2	161	107	36,5
GLV 630 Q2	240,0	186	GLV 630 E2	263,75	209,76	GLV 630 W2	172	118	47,0
GLV 800 Q2	254,0	200	GLV 800 E2	277,75	223,76	GLV 800 W2	185	132	61,0

# FLUID POWER



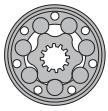

## DIMENSIONI E FLANGIA / DIMENSIONS AND MOUNTING

### U Flangia Ultracorta Very Short Mount

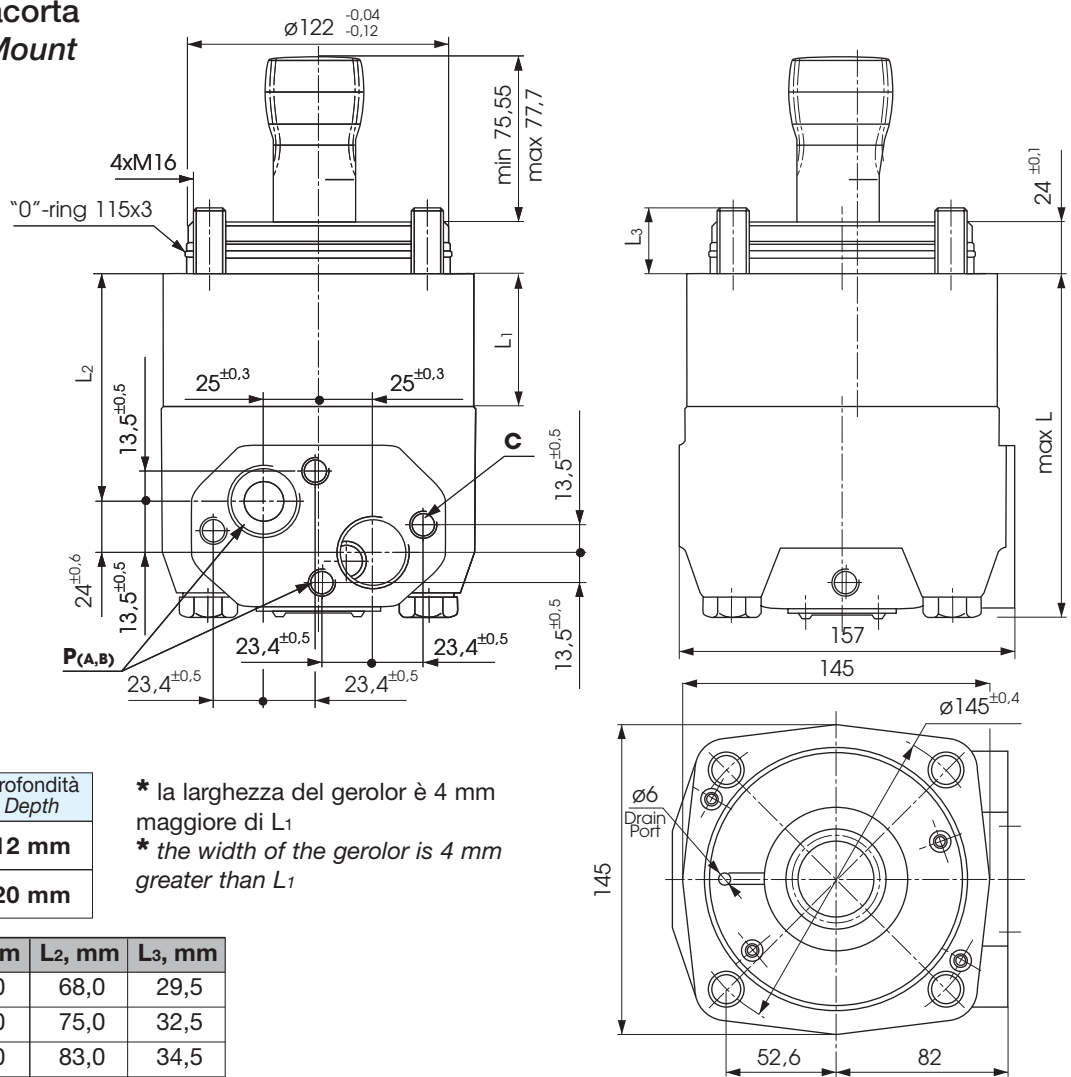

	Filettatura/Thread	Profondità Depth
C	4 x M12	12 mm
A, B	2 x G 1"	20 mm

\* la larghezza del gerolor è 4 mm maggiore di  $L_1$   
\* the width of the gerolor is 4 mm greater than  $L_1$

Tipo / Type	L, mm	$L_1^*$ , mm	$L_2$ , mm	$L_3$ , mm
GLV 315 U2	121,5	22,0	68,0	29,5
GLV 400 U2	128,5	29,0	75,0	32,5
GLV 500 U2	136,5	37,0	83,0	34,5
GLV 630 U2	147,0	47,5	93,0	34,0
GLV 800 U2	161,0	61,5	107,5	30,0

## DIMENSIONI DI ACCOPIAMENTO / DIMENSIONS OF THE ATTACHED COMPONENT

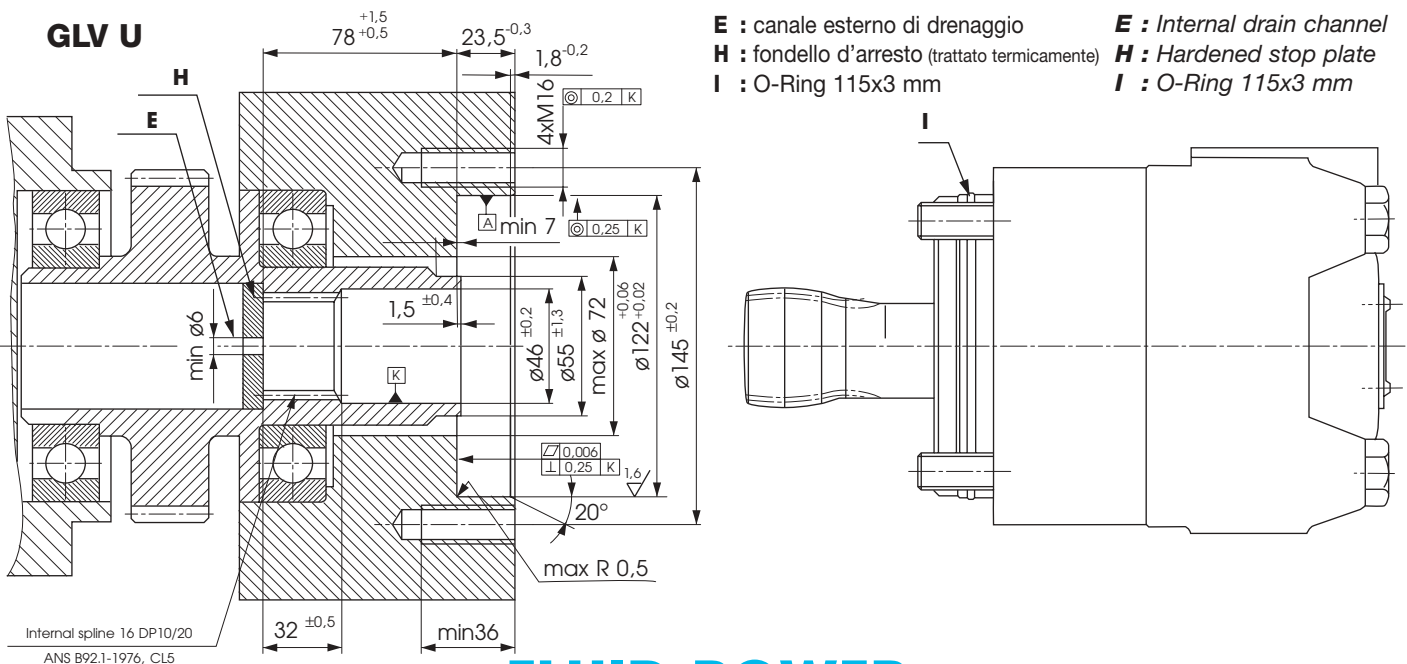

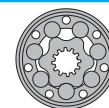

## DRENAGGIO / DRAIN CONNECTION

Il collegamento del drenaggio può essere usato quando la pressione nella linea di ritorno supera la pressione permessa. Può essere collegato:

- per GLV ...C all'attacco del drenaggio del motore
- per GLV ...U all'attacco del drenaggio del componente a cui è collegato il motore. La pressione massima nella linea di drenaggio è limitata dal valore accettato dai componenti a cui è collegato il motore e dalle tenute albero del motore stesso. Il drenaggio deve permettere all'olio di scorrere liberamente tra il motore ed il componente collegato e deve essere diretto al serbatoio

A drain line ought to be used when pressure in the return line can exceed the permissible pressure: It can be connected:

- for GLV ...C at the drain port of the motor;
- for GLV ...U at the drain connection of the attached component. The maximum pressure in the drain line is limited by the attached component and its shaft seal. The drain line must be possible for oil to flow freely between motor and attached component and must be led to the tank. The maximum pressure in the drain line is limited by the attached component its seal.

## DATI DELLA SCANALATURA INTERNA INTERNAL SPLINE DATA FOR THE ATTACHED COMPONENT

Standard ANSI B92.1 – 1976 CLASSE 5 (m=2.1166; corretto x.m = + 1.0)      Standard ANSI B92.1-1976, CLASS 5 (m=2.54; corrected x.m = + 1,0)

Ingranaggio di accoppiamento	Fillet Root Side Fit	mm
Numero di denti	Number of Teeth	16
Passo	Diametral Pitch	10/20
Angolo di pressione	Pressure Angle	30°
Diametro passo	Pitch Dia.	40,640
Diametro esterno	Major Dia.	45,2 <sup>+0,4</sup>
Diametro interno	Minor Dia.	38,5 <sup>+0,039</sup>
Larghezza vano (circolare)	Space Width (circular)	5,18 <sup>±0,037</sup>
Raggio di raccordi	Fillet Radius	0,4
Max. misurazione tra rullini	Max. Measurement between Pin	32,47 <sup>+0,15</sup>
Diametro rullino	Pin Dia.	5,5 <sup>±0,001</sup>

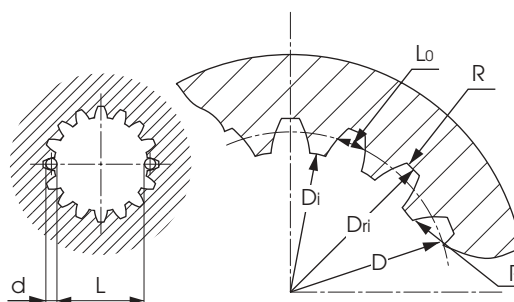

Specifiche del trattamento termico di indurimento:  
HRC 60 ± 2  
0,7 ± 2 mm effettiva profondità  
Materiale 20MoCr4 DIN 17210 o migliore

Hardening specification:  
HRC 60±2  
HRC 52  
0,7±2 mm effective case depth  
Material 20 MoCr4 DIN 17210 or better

## MOTORE CON ATTACCO TACHIMETRICO / MOTOR WITH TACHO CONNECTION

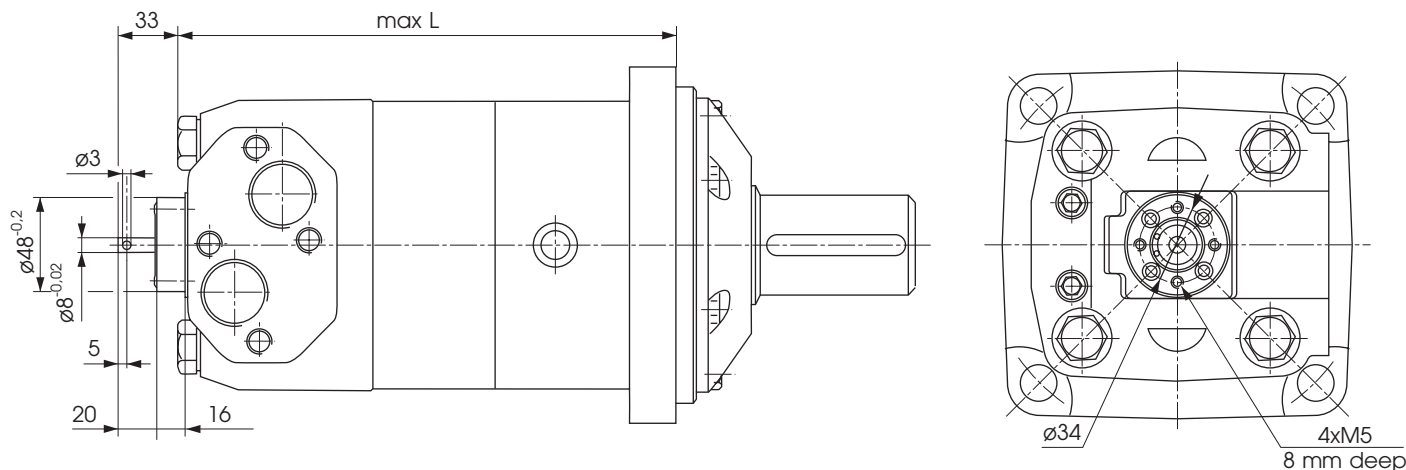

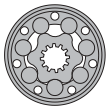

## DIMENSIONI ALBERI / SHAFT DIMENSIONS

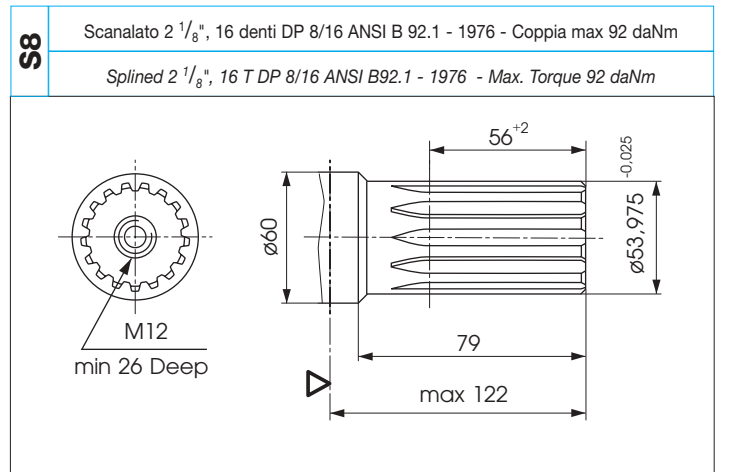
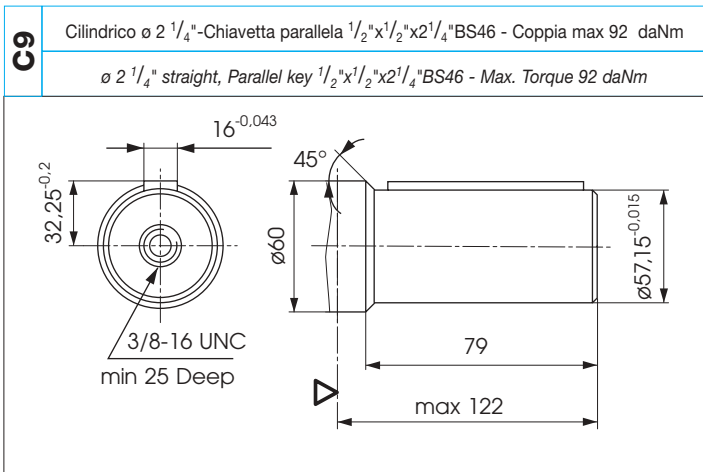
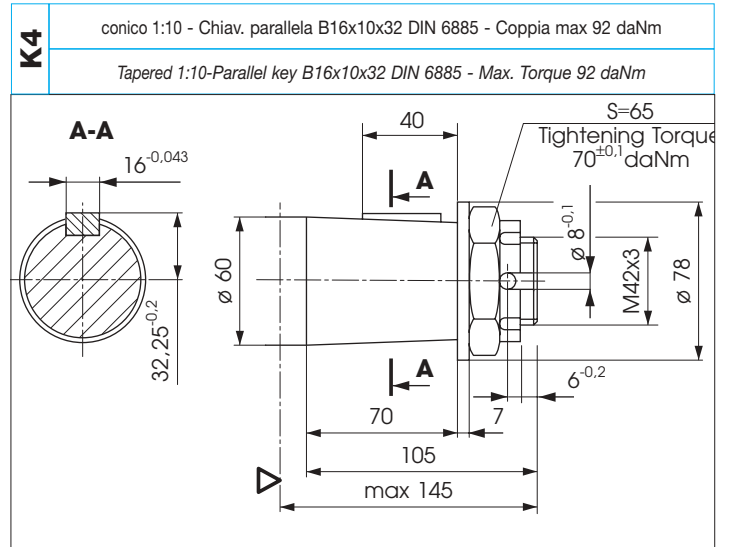
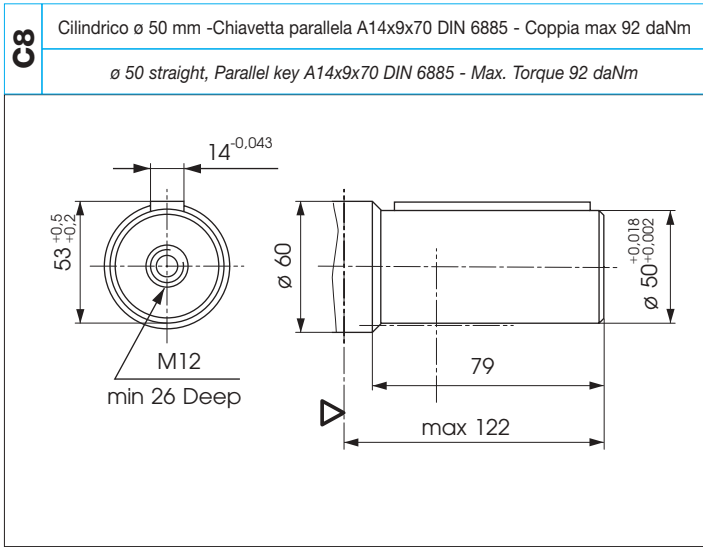

▽ - Flangia di attacco del motore  
 - Motor mounting surface

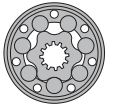

## SIGLA DI ORDINAZIONE / ORDER CODE

**GLV 315 C8 Q \_**

Serie/Series

Cilindrata / Displacement	
315	314,5 cm <sup>3</sup> /rev
400	400,9 cm <sup>3</sup> /rev
500	499,6 cm <sup>3</sup> /rev
630	629,1 cm <sup>3</sup> /rev
800	801,8 cm <sup>3</sup> /rev

Versioni speciali /Special features

Vedere pag. 122-123-124  
See page 122-123-124

Flangia/Mounting Flange

- Q** Flangia quadrata 4 fori /Square Mount, 4 holes
- E** Flangia SAE C /SAE C Mount
- C** Flangia Corta /Short Mount
- U** Flangia ultracorta /Very short Mount
- W** Flangia ruota /Whell Mount

Albero / Shaft\*

<b>C8</b>	Cilindrico ø 50 mm - Chiavetta parallela A14x9x70 DIN 6885 ø 50 straight, Parallel key A14x9x70 DIN 6885
<b>C9</b>	Cilindrico ø 2 1/4" - Chiav. parallela 1/2"x1/2"x2 1/4" BS46 ø 2 1/4" straigh - Parallel key 1/2"x192"x2 1/4" BS46
<b>K4</b>	ø 60 conico 1:10 - Chiavetta parallela B16x10x32 DIN 6885 ø 60 tapered 1:10 - Parallel key B16x10x32 DIN 6885
<b>S8</b>	Scanalato 2 1/8", ANSI B92.1 - 1976 Splined 2 1/8", ANSI B92.1 - 1976

\* **NOTA:** La coppia ammessa sugli alberi non deve essere superata

\* **NOTES:** the permissible output torque for shafts must not be exceeded